



Reference Joseph Beuys Plight, 1985

Planning the winter utilization of a barn in Csíkdelne

The barn, as an ancient structure formed of old posts and beams, serves as a testament to past agrarian culture. Its original purpose for hay storage has evolved, and today it serves as a venue for events and celebrations in the warmer months of the year. It is intended for the barn space to provide a warm and weather-proof environment during the winter months as well.

The objective of this intervention is not only to make the barn ready for winter, but also to emphasize the archaic form of the barn. In a process of metamorphosis, a thick, weather-resistant textile such as felt or hemp is stretched inside the barn. Thus a festive space is created, in a similar way to Karl Friedrich Schinkel's tent room, showcasing both the barn's ancient form of construction, and the essence of its history. The thick fabric serves not only as insulation against the cold, but also to improve the acoustic properties inside the barn, and to act as sound insulation to the outside.

The fabric, which can be wound up in a similar way to a roller-shutter, can be rolled up or down quickly, allowing for rapid transformation, such as providing sound insulation for an event. The light attachment mechanism of the roller interferes only minimally with the existing structure of the barn. The adaptability of the intervention means that the beauty of the old barn can be experienced time and time again.

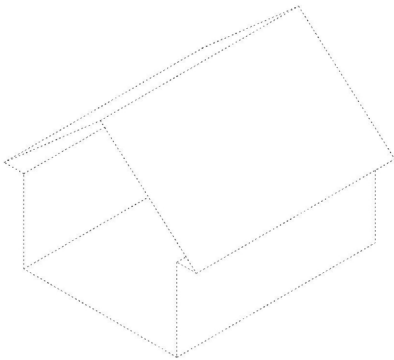

existing shell

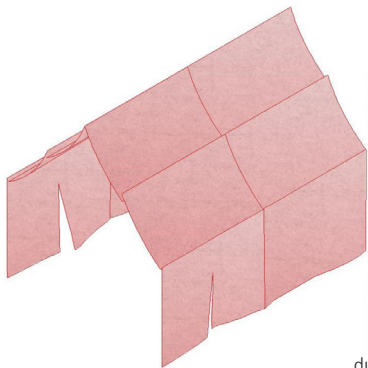

warm tent during winter time

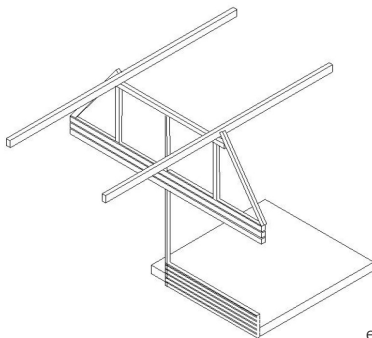

staging the existing structure

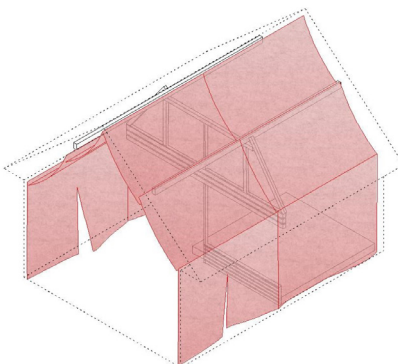

isometric



Reference Karl Friedrich Schinkel, Schloss Charlottenhof, 1830

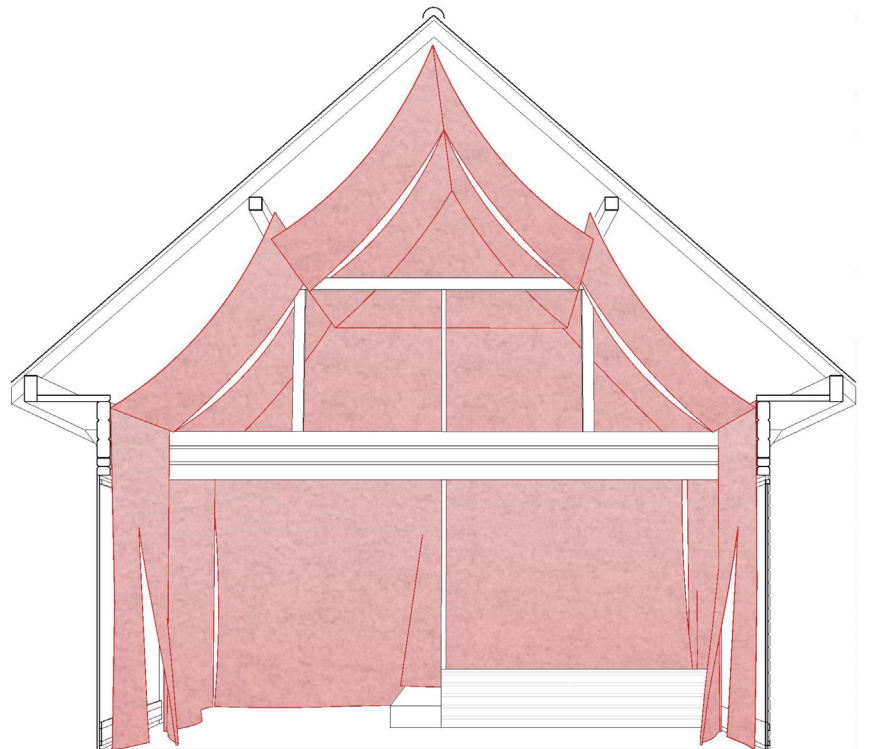

perspective